

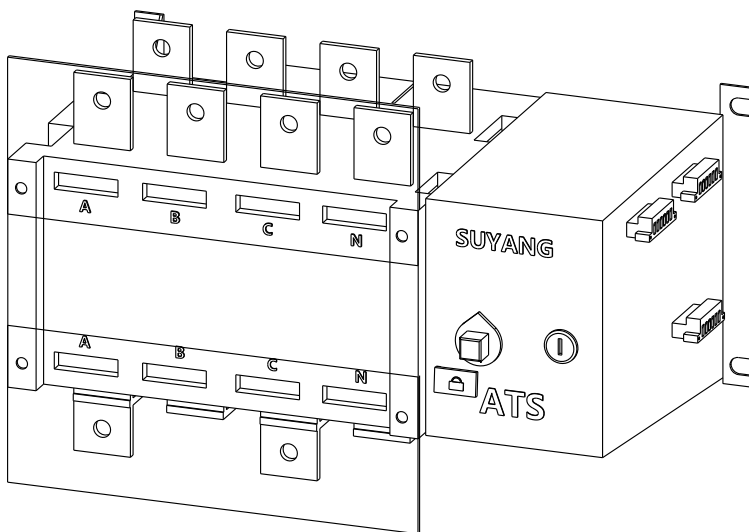

instruction for use

ATS-series

Automatic transfer switch



ATSE only be installed in the right place, be installed, debugged and maintained by special person. All operations (installation, connect must comply with this instruction. All ATSE on sale are marked and with complex construction. Anyone open it by himself without permission does so at his own risk.

1. Overviews

1.1 The general

Suitable for AC 660 v and below, rated frequency 50 Hz, whether it is normal or not. As long as within the technical parameters of the switch, all can be guaranteed safely and reliably operate in the corresponding voltage grades of occasions.

1.2 Service conditions

1.2.1 ambient air temperature

A) the highest temperature $\leq + 60^{\circ}\text{C}$:

B) the lowest temperature $\geq - 20^{\circ}\text{C}$

C) the highest average temperature $\leq + 60^{\circ}\text{C}$

D) the ambient air temperature is higher than $+ 60^{\circ}\text{C}$ or below -20°C the user should negotiate with the manufacturer.

E) environmental temperature $> 60^{\circ}\text{C} \leq 80^{\circ}\text{C}$ should reduce capacity selection (off about 20%);

1.2.2 atmospheric temperature

When the highest temperature $+ 60^{\circ}\text{C}$ relative humidity $\leq 50\%$. Moist air on the sea will influence capability when the max monthly RH is 90%.

1.2.3 installation elevation

The installation elevation ≤ 2000 m. When used in higher altitudes, the user should check with the manufacturer as decrease of electric strength and cooling action.

1.2.4 pollution levels

Class of pollution: class 3.

1.2.5 installation category

Installation category as class IV.

1.2.6 installation tilt

ATSE is a rack fixed installation, installation tilt $\leq \pm 22.5$.

1.2.7 use categories: AC - 33 ib

1.2.8 the model means

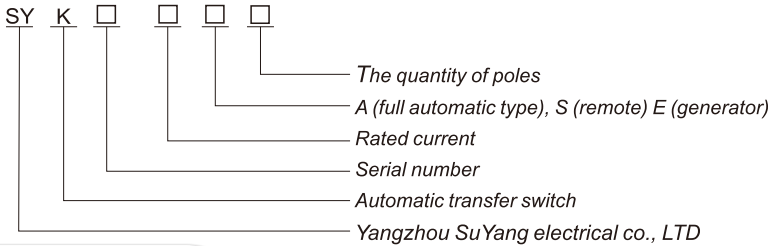

1.3 Product features

1.3. 1 installation performance is good

1.3. 2 with double row composite contact, horizontal pull-out mechanism micromotor energy storage and microelectronic control technology, the basically zero arcing (no arc clute)

1.3. 3 use reliable mechanical interlock and electric interlock, ensure higher Security

1.3. 4 using a zero technology, an emergency can be forced to zero at the same time to cut off the two power supplies

1.3. 5 has obvious on/off position indicator, padlock, and other functions. Insulate the power and the load reliably. With high reliability and more than 10000 times using life.

1.3. 6 good electromagnetic compatibility, strong anti-interference ability, no interference

1.3. 7 high automaticity

1.3. 8 switch has multiple input/output interface, easy to implement remote PLC control and system automation. Switch can work without any other controller.

1.3. 9 beautiful shape, small volume, light weight. The logic control board can control operation of the motor(inside the switch)using differentlogic to make sure the switch on it's position.

1.3 Features

ATSE series as the main, dual power automatic transfer switch is mainly used in the first class load and second class load (which need back-up power) confirmed by the national regulations, suitable for highrise buildings, post and telecommunications, coal and shipping, industrial assembly line, health care, military facilities, etc. The main standby power can be grid, generator, battery, etc. The main standby power can be customized by users. Transfer time of the main switch body is not more than 1s. Users can make special delay when necessary. The main power takes priority over the main standby power when supply electricity together.

2.1 The main technical parameters

Meet IEC947-6-1 / GB 14048. 11

Rated thermal current	80A	100A	125A	160A	250A	400A	630A	800A	1000A	1250A	1600A	2000A	2500A	3200A	
Rated insulation voltage	750V					1000V									
The rated impulse withstand voltage	8KV					12KV									
Rated operational voltage	AC440V														
The rated working current	AC38B	80	100	125	160	250	400	630	800	1000	1250	1600	2000	2500	3200
Rated making ability	10Ie														
The rated breaking capacity	8Ie														
Rated conditional short-circuit current	100KA					70KA		100KA			100KA		80KA		
Rated short-time withstand current	7KA		9KA			13KA		50KA					55KA		
Conversion time	≤0.45S		≤0.45S			≤0.6S		≤1.2S					≤1.4S		
	≤3S(YC type)		≤3.5S(YC type)												
The supply voltage	Standard: AC 220 v, customizable AC110V, AC380V, DC12V DC24V														

2.2 switch structure

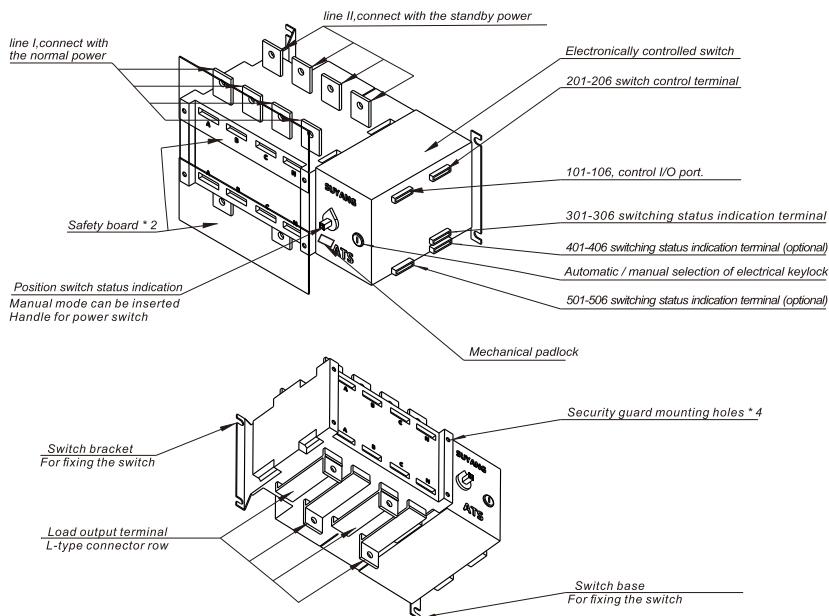

2.3 Terminal function

Terminal no.	Node number	Features	Explanation
No. 1 terminal	101、106	Power zero line, FireWire Out	Active output, 1AAC220V
	102、103	I work way power zero line, FireWire input	AC 220V
	104、105	II work way power zero line, FireWire input	AC 220V
No. 2 terminal	201、206	Disconnect passive control, closed for the active control	See SYK1 type Schematic
	202	External passive control signal input common	
	203	I closed the road and after 202 Closing	
	204	0 closed the road and after 202 Closing	I / II line open
	205	II closed the road and after 202 Closing	
No. 3 terminal	301、306	Unused, even inside has been	400A above assembly
	302	Passive position feedback signal output common	The basic model is an active output, other Model passive output,
	303	I closed the road after closing and 302	
	304	0 closed the road after closing and 302	
	305	II closed the road after closing and 302	
No. 4 terminal	401、406	Unused, even inside has been	400A above assembly
	402、403	I closed the road after closing	Passive 1AAC220V
	404、405	II closed the road after closing	Passive 1AAC220V
No. 5 terminal	501~506	Custom signal output terminal	400A above assembly Passive 1AAC220V

1, Electric lock: control the power of control circuit inside the switch. When the electric lock turned on, the switch can be remotely operated, otherwise the switch will be hand operation.

2, Operation handle: electric lock must be closed when using operation handle.

3, Mechanical padlock: Before you overhaul, you must turn off the electric lock, use the operating handle to force the switch to "0" position, pull the mechanical padlock and lock it.

4, Position indicator: indicate working status of the switch(I,0,II).

5, The control voltage: AC220V.

6, The switch body: part in the front is line I, connect with the normal power. Part at the back is line II, connect with the standby power.

2.4 correct installation schematic diagram

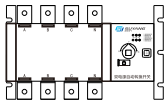

Correct installation

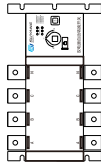

Correct installation

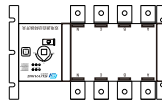

Correct installation

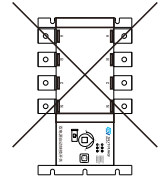

Error Installation

2.5 Installation size

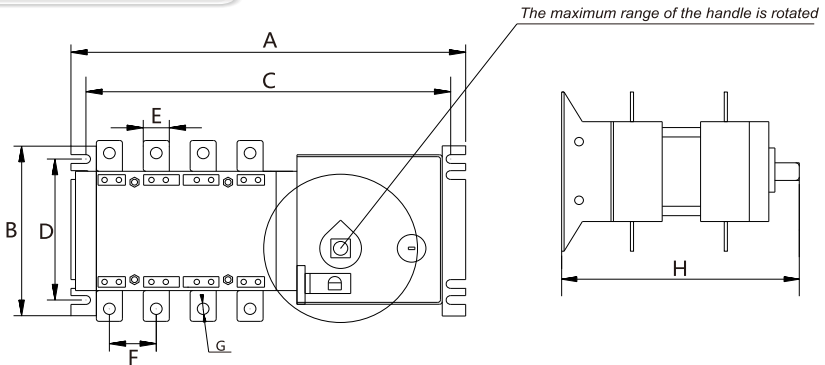

Model Specifications	A	B	C	D	E	F	G	H
SYK2-20-100A	245	106	233	84	14	30	6	133
SYK1-20-160A	303	135	280	110	20	36	9	195
				80				190
SYK1-200-300A	360	160	345	110	25	50	11	195
				80				
SYK1-400-630A	435	260	415	180	40	65	13	262
SYK1-800-1000A	635	326	610	220	63	120	9	321
SYK1-1250A	635	326	610	220	63	120	11	321
SYK1-1600A	635	360	610	220	80	120	13	321
SYK1-2000-3200A	635	400	475	350	80	120	13	505

2.6 all types of wiring

SYK1 / SYK2 series dual power typical control schematics

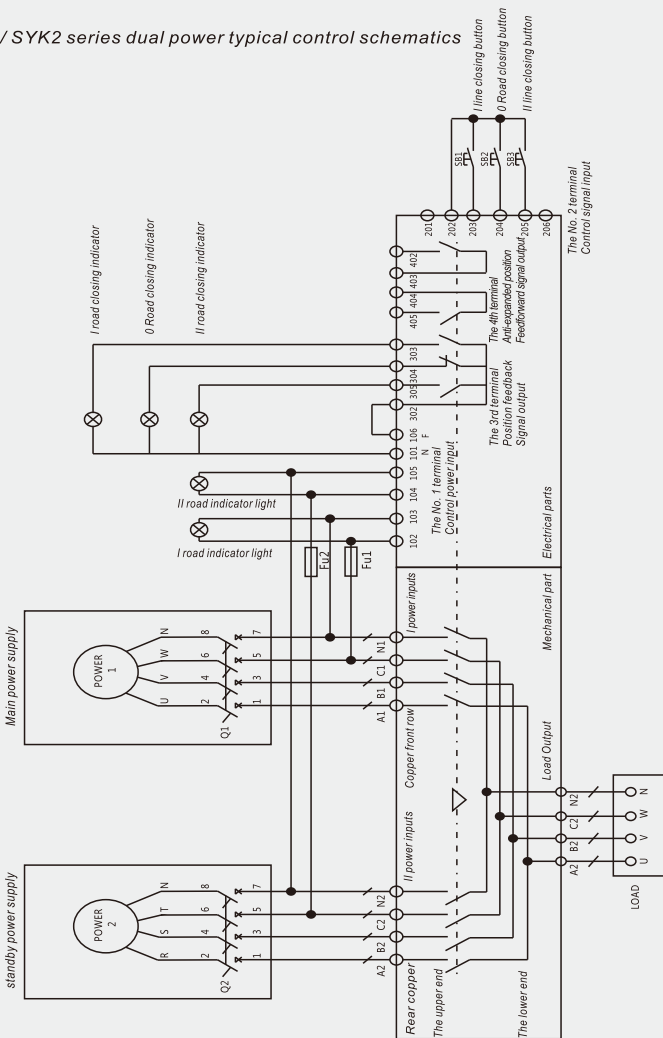

Fu1 / FU2 is 2A fuse

101 to 106, 201-206, 301-306 as SYK switch terminal

630A switch terminal can be used for more than 401-406, 501-506

Note: This wiring diagram applies and 2, 3, 4, 5

Explanation:

1. the drawing applies only to standard ATS switches at the access switch bronze voltage: AC380 / 220V (three-phase four-wire), in the case of 50 / 60Hz use.
2. the use of intelligent controller, use the 3rd terminal access controller as a feedback signal port, use the 4th port terminal as an external indicator

1. the automatic wiring (basic)

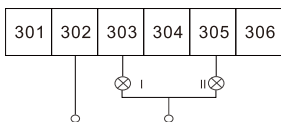

220V input load side switch status indicator

● I main power indicator ● II standby power indicator

2. automatic wiring

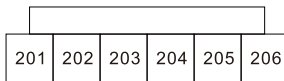

Automatic Wiring

3. Automatic + forced zero protection (fire fighting, dual power supply are disconnected)

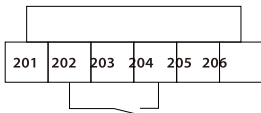

Forced zero contacts Passive input

4. Remote control (manual only) Wiring

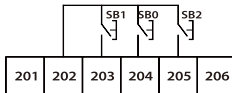

Sb1, SB0, SB2 respectively common power, forced to zero, spare Power-control buttons (passive contact)

5. Automatic + Manual (remote control) Wiring

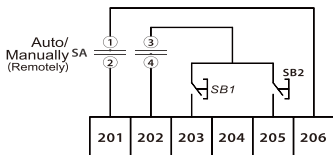

SA is the switch choose automatic or manual mode.
SB1 is the manually input button for main power. (passive contact).
SB2 is the manually input button for standby power (passive contact).

6. the starter-generator signal wiring

Has brought a generator interface (301-306 words have UGE1),
Wiring diagram is as follows

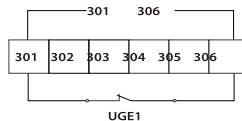

UGE1 passive contact connected generator Interface

Description: UGE1 internal AC220V relay to switch 301 306 starter generator Interface

NOTE: The above is about "the 2nd switch terminal" control wiring, the user can choose one, just to copper automatic power introduced, do not need another then the second line, 302-305 switching state instructions, such as users need to connect their own. Terminal method: only one set of six terminals

7. Generator connection mode

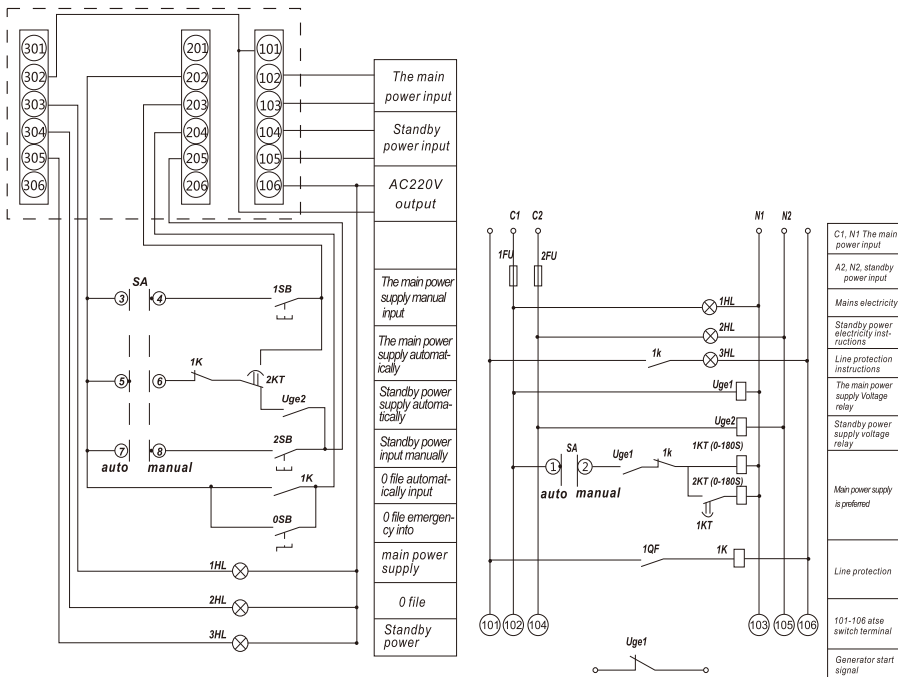

Note: 101-106 for switching power supply input and output terminals

201-206 for switch control terminals

301-306 for the switch status indication terminal

1 Qf primarily circuit (mains) protection switch alarm contacts

1 Kt for power on delay (0-180s), 2 kt for power off delay (0-180s)

3.1 switch wiring instructions (see 2.2 switch structure)

3.1. 1 switch from left to right, I copper busbar connect with A, B, C, N of Commonly used power(in the front) and II connect with standby power(at the back).

3.1. 2 control power is taken from C of commonly used power and N of stand by Power

3.1. 3 .control power AC220V of line I connect to terminal 102~103,control power AC220V of line II connect to terminal 104~105. 102 is fire wire for commonly used power and 104 is fire wire for standby power.

3.1. 4 terminal 101,106, just as a light control power, of which 106 is fire wire.

Note that 101, 106 can not connected to any other lines!

3.1. 5 When the top(bottom) of line I inset wire, A,B,C,N at the bottom (top) use connection of copper busbar to output it. And line II use wires.

4.1 common problems and solutions.

	Problems	Reasons	Solutions
1	<i>Power on, ATs does not work</i>	1. Whether the button pressed on the automatic position	<i>Choose the automatic position</i>
		2. Whether working power of the switch is connected	<i>Access to the control power correctly</i>
		3. 2. if connection mode of terminal 2 is correct	<i>Access to signal control line correctly</i>
		4. The fuse is damaged	<i>Replacing the fuse</i>
2	<i>Power on, circuit board burned</i>	check line 101-106 to make sure it is normal	<i>Replace the circuit board</i>

Schedule

Packing List

ATS / 1 station, machinery operating handle / 1 set, cable fixing bolts / 1 set,
Security guard / 1 set (optional)
Manual, single factory inspection, certification

Mount the cabinet reference Dimensions

Current (A)	The maximum length switch Lmax(mm)	The maximum width switch Wmax(mm)	The maximum height switch Hmax(mm)	Recommended cabinet (L * W * H mm)
2000-3200	635	505	470	800*800*2200
1600	635	321	407	800*600*2200
800-1250	635	321	350	800*600*1800
400-630	435	262	270	600*500*1500
250	360	195	170	500*400*1200
125-160	303	195	142	
20-100	245	133	106	

Explanation:

- 1, the maximum length Lmax switch mounting bracket to the left to the right and left vertical surface mounting distance holder the right facade.
- 2, the maximum width Wmax switch after mounting bracket to the front façade manual emergency handle the interface facade distance.
- 3, switch on the maximum height Hmax of copper facade from the top to the bottom of the facade at the bronze medal.
- 4, the height of the cabinet space required, please consider the actual situation isochronous operation and connecting cables.

 As time goes on constantly, constantly updated technology, subject to change without further notice, product image if there is a difference in kind, please prevail in kind, The Company reserves the right of final interpretation and modification of information!

 Cherish resources, treat the environment

TRACING SUYANG QUALITY ROCK SOLID

YANGZHOU SUYANG ELECTRIC CO.,LTD

 Yongxun Road 1, Dayi Industrial Zone,
Dayi Town, Yangzhou, Jiangsu, China

 +86 0514-82888885

 +86 400-888-5848

 <http://www.yzsuyang.cn>